

Rod Ends Series K - Maintenance Free

Series GAXSW

Rod Ends with male thread made from heat-treated steel, zinc plated with PTFE liner, maintenance free

For use at high pressure and tension loads

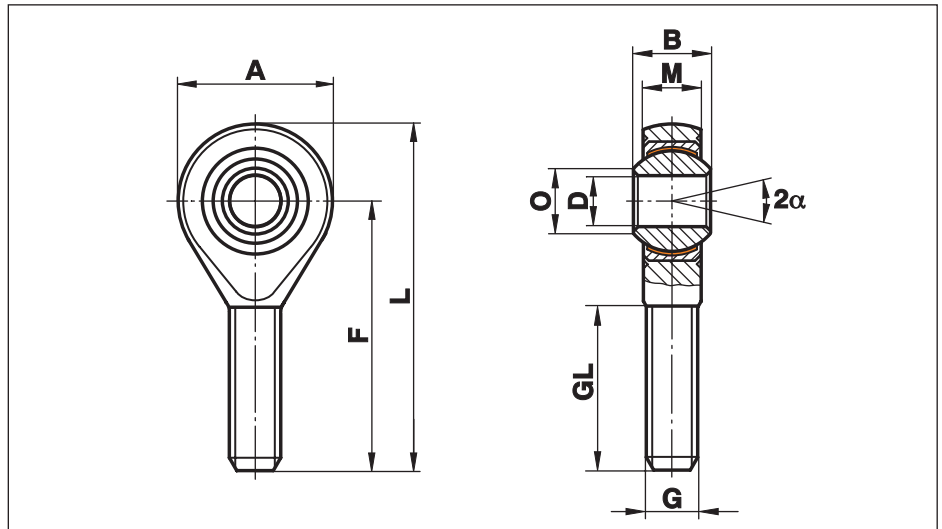

Size (D)	B	M	A	F	L	O	G	GL	Static load C ₀ kN	Dynamic load C kN	Limiting speed rev/min	Weight g
6	9	6,75	20	36	46	8,9	M 6	22	9,8	9,3	530	20
8	12	9,00	24	42	54	10,4	M 8	25	19,5	16,7	420	33
10	14	10,50	28	48	62	12,9	M 10	29	31,4	23,4	350	56
12	16	12,00	32	54	70	15,4	M 12	33	42,0	32,0	300	87
14	19	13,50	36	60	78	16,8	M 14	38	57,0	42,0	260	129
16	21	15,00	42	66	87	19,3	M 16	40	67,0	52,5	230	189
18	23	16,50	46	72	95	21,8	M 18x1,5	44	81,5	64,0	210	267
20	25	18,00	50	78	103	24,3	M 20x1,5	47	93,5	78,0	190	348
22	28	20,00	54	84	111	25,8	M 22x1,5	51	114,0	97,0	170	443
25	31	22,00	60	94	124	29,6	M 24x2	57	135,0	122,0	150	600
30	37	25,00	70	110	145	34,8	M 30x2	71	184,0	168,0	130	1030
35	43	28,00	80	125	165	37,7	M 36x2	73	230,0	205,0	110	1600

only for short-term revolutions recommended

Materials:

Housing: Heat-treated steel to 42CrMo4, Aisi 4140, forged

Insert: Free-cutting steel to 9SMnPb28K, 12L13, with PTFE liner bonded to the inner surface

Ball: Bearing steel to 100Cr6, Aisi 52100, hardened, ground, polished

This series is also available sealed (see page 38) or with threaded bolt (see page 39).